

DIN-Rail Mount SMPS

SPB-A Series INSTRUCTION MANUAL

TCD230001AC

Autonics

Thank you for choosing our Autonics product.

Read and understand the instruction manual and manual thoroughly before using the product.

For your safety, read and follow the below safety considerations before using.

For your safety, read and follow the considerations written in the instruction manual, other manuals and Autonics website.

Keep this instruction manual in a place where you can find easily.

The specifications, dimensions, etc. are subject to change without notice for product improvement. Some models may be discontinued without notice.

Follow Autonics website for the latest information.

Safety Considerations

- Observe all 'Safety Considerations' for safe and proper operation to avoid hazards.
- ⚠ symbol indicates caution due to special circumstances in which hazards may occur.

⚠ Warning Failure to follow instructions may result in serious injury or death.

- Fail-safe device must be installed when using the unit with machinery that may cause serious injury or substantial economic loss.** (e.g. nuclear power control, medical equipment, ships, vehicles, railways, aircraft, combustion apparatus, safety equipment, crime / disaster prevention devices, etc.)
Failure to follow this instruction may result in personal injury, economic loss or fire.
- Do not use the unit in the place where flammable / explosive / corrosive gas, high humidity, direct sunlight, radiant heat, vibration, impact, or salinity may be present.**
Failure to follow this instruction may result in explosion or fire.
- Connect the ground completely to the PE terminal.**
Failure to follow this instruction may result in electric shock or malfunction.
- Do not connect, repair, or inspect the unit while connected to a power source.**
Failure to follow this instruction may result in fire or electric shock.
- Check 'Wiring Diagram' before wiring.**
Failure to follow this instruction may result in fire, electric shock or product damage.
- Do not disassemble or modify the unit.**
Failure to follow this instruction may result in fire, electric shock or product damage.

⚠ Caution Failure to follow instructions may result in injury or product damage.

- When connecting the terminal, tighten the terminal screw with a tightening torque of 0.3 to 0.5 N·m.**
Failure to follow this instruction may result in fire or malfunction due to contact failure.
- Use the unit within the rated specifications.**
Failure to follow this instruction may result in fire, product damage or shortening the life cycle of the product.
- Use the device within the output derating curve by ambient temperature.**
Failure to follow this instruction may result in product damage or shortening the life cycle of the product.
- Use dry cloth to clean the unit, and do not use water or organic solvent.**
Failure to follow this instruction may result in fire or electric shock.
- Keep the product away from metal chip, dust, and wire residue which flow into the unit.**
Failure to follow this instruction may result in fire or product damage.
- Do not touch the product during operation or for a certain period of time after stopping.**
Failure to follow this instruction may result in burns.
- Upon occurrence of an error, disconnect the power source.**
Failure to follow this instruction may result in fire or product damage.
- Insert the twisted pair cable completely into the terminal block.**
Failure to follow this instruction may result in fire or product damage.
- Do not use the inverter output as a voltage input.**
Failure to follow this instruction may result in fire due to rapid switching.
- Do not use the device in conditions where inrush current or overload occurs frequently.**
If short circuit or overcurrent condition is continued, it may result in fire or product damage.
- Use an external diode when using it to operate a motor, etc.**
If the voltage output exceeds the rated output voltage range, it may result in malfunction or product damage.
- Use an external diode for serial/parallel operation.**
Failure to follow this instruction may result in fire or product damage due to the reverse voltage generated inside the SMPS when the load is short-circuited.
- In case of serial/parallel operation, make sure that the current over the rated current does not flow to the SMPS.**
Failure to follow this instruction may result in product damage.

Cautions during Use

- Follow instructions in 'Cautions during Use'. Otherwise, it may cause unexpected accidents.
- In the case of models with power of 120 / 240 / 480 W, noise may occur when power is input until the internal circuit stabilizes.
- When connecting the output terminal, cable length should be less than 30 m.
- If large current flows, use multiple terminal blocks.
- Do not use more than two output voltages in parallel and series connection.
- Install the device in a well-ventilated area. Install a cooling fan additionally in a poorly ventilated environment.

- There is a noise filter inside the device, but in an environment where a lot of noise occurs, install an additional noise filter outside.
- Install the device perpendicular to the ground.
- It may cause deterioration or damage to internal parts, and may affect specifications.
- If the device used at frequent inrush currents or overloads at the load end environments, internal parts may deteriorate or be damaged.
- Short-circuit or over-current conditions must not continue during operation. Internal parts may deteriorate or break.
- Do not turn the output voltage adjustment adjuster (VAdjust) with excessive force. It may result in damage.
- Do not use near the equipment which generates strong magnetic force or high frequency noise.
- This unit may be used in the following environments.
 - Indoors (in the environment condition rated in 'Specifications')
 - Altitude max. 2,000m
 - Pollution degree 2
 - Installation category II

Ordering Information

This is only for reference, the actual product does not support all combinations. For selecting the specified model, follow the Autonics website.

SPB	-	A	①	-	②
① Power					
Number: Power (unit: W)					
② Output voltage					
Number: Output voltage (unit: VDC≐)					

Product Components

- Product × 1
- Instruction manual × 1

Sold Separately

- Bracket: BK-SPB-F01 (SPB-A015 / 030 / 060-□)
BK-SPB-F02 (SPB-A120 / 240 / 480-□)

Dimensions

- Unit: mm, For the detailed drawings, follow the Autonics website.

■ SPB-A015-□

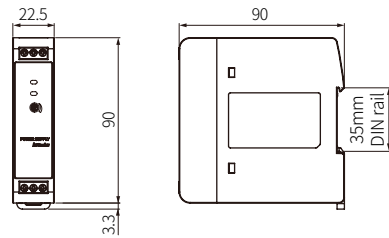

■ SPB-A030 / 060-□

- This is based on SPB-A060 model.

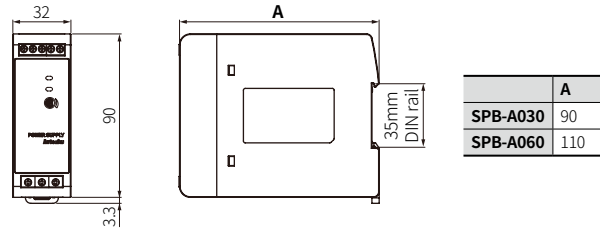

■ SPB-A120 / 240-□

- This is based on SPB-A120 model.

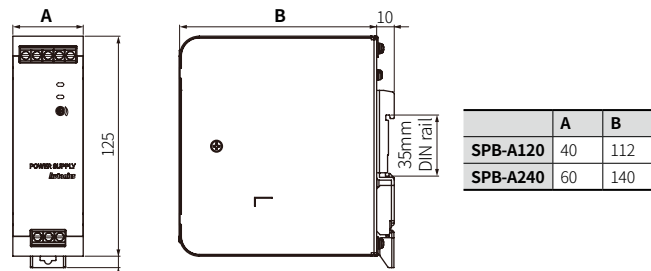

■ SPB-A480-□

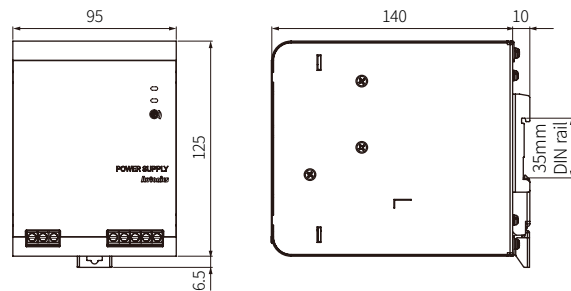

Unit Descriptions

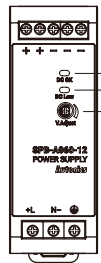

- Output indicator (DC OK, green)**
: Turns ON during normal operation after power input.
Flashes when overcurrent protection function operates.
- Output low voltage indicator (DC Low, red)**
: Turns ON when output voltage is lower than reference value.

Output voltage [VDC≐]	5	12	24	48
Output low voltage indicate [VDC≐]	4.2 (± 10%)	9.6 (± 10%)	20.0 (± 10%)	43.0 (± 10%)

- Output voltage adjuster (VAdjust)**
: Adjust this volume within voltage variable range. It is not guaranteed when using outside the variable range.

Connection

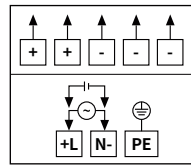

Mark	Function
+	Output power (+)
-	Output power (-)
+L, N-	Input power
⊕	Protective Earth (PE)

Model	Wire specification			Terminal	Torque
	Output	Input	PE		
SPB-A015-05 ⁽⁰¹⁾	AWG 20 to 12				M2.5
SPB-A015-12 ⁽⁰¹⁾	AWG 22 to 12	AWG 24 to 12			
SPB-A015-24 ⁽⁰¹⁾	AWG 24 to 12				M2.5
SPB-A030-05 ⁽⁰¹⁾	AWG 18 to 12		AWG 14 to 12		
SPB-A030-12	AWG 20 to 12	AWG 24 to 12			M2.5
SPB-A030-24	AWG 22 to 12				
SPB-A060-12	AWG 18 to 12	AWG 22 to 12			0.3 to 0.5 N·m
SPB-A060-24	AWG 20 to 12				
SPB-A120-12	AWG 14 to 10	AWG 22 to 10			M3
SPB-A120-24	AWG 18 to 10				
SPB-A240-12	AWG 12 to 10	AWG 12 to 10			M3
SPB-A240-24	AWG 14 to 10	AWG 20 to 10	AWG 14 to 10		
SPB-A480-24	AWG 12 to 10				M3
SPB-A480-48	AWG 14 to 10	AWG 16 to 10			

- There are one + terminal and two - terminals.
The rated current is 10 A per output terminal. If the rated current is exceeded, use multiple terminals at the same time.

Mounting

- It can be mounted on a 35 mm DIN rail conforming to EN 60715 standards.
- Depending on the installation environment, screw installation is available using the bracket (sold separately).

■ Mounting with DIN Rail

Put the product on DIN rail and press it to the direction ①.

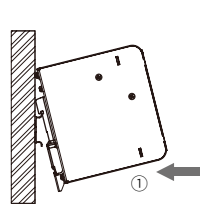

■ Removing with DIN Rail

Push the latch to the direction ① with a tool and pull the bottom of the device in the direction ②. Left it in direction ③.

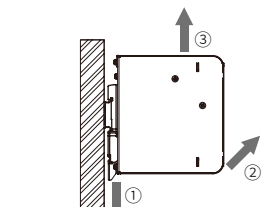

Cautions during Installation

⚠ High Temperature Caution
While supplying power to the load or right after turning off the power of the load, do not touch the body. Failure to follow this instruction may result in a burn due to the high temperature.

■ Mount space

- When installing adjacently to multiple SMPS or heating devices, keep space between power controllers for heat radiation.
Horizontal: ≥ 20 mm,
Vertical: ≥ 40 mm

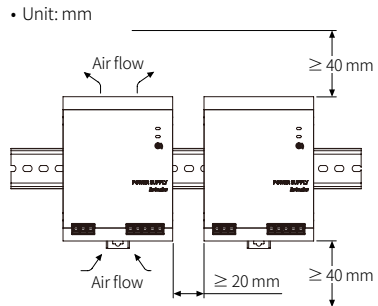

Specifications

Indicator	Output indicator (green), output low voltage indicator (red)				
Over-current protection	≥ 121%				
Over-voltage protection⁽⁰²⁾	≈ 130%				
Output short-circuit protection	Built-in				
Overheat protection	Built-in				
Parallel operation⁽⁰³⁾	Available				
Insulation resistance	Among all input terminals and all output terminals and PE : ≥ 100 MΩ (500 VDC≐ megger)				
Dielectric strength	Among all input terminals and all output terminals: 3 kVAC~, Cutoff current = 20 mA Among all output terminals and PE: 1 kVAC~, Cutoff current = 20 mA				
Vibration⁽⁰⁴⁾	10 to 55 Hz, 0.75 mm double amplitude, in each X, Y, Z direction for 2 hours				
Shock	150 m/s ² (≈ 15 G) in each X, Y, Z direction for 3 times				
EMS	Conforms to EN61000-6-2				
EMI	Conforms to EN61000-6-4				
Ambient temperature⁽⁰⁴⁾	-20 to 70 °C, storage: -25 to 80 °C (no freezing or condensation)				
Ambient humidity	20 to 90%RH, storage: 20 to 90%RH (no freezing or condensation)				
Protection structure	IP20 (IEC standard)				
Certification⁽⁰⁵⁾	CE, ENEC, UL, VDE, TUV				

- To reset the overvoltage protection, shut off input power for at least 5 minutes and then restart.
- For more information, refer the product manuals.
- Applies when the device is installed vertically to the ground. For non-vertical installation, secure the product to withstand vibration and shock.
- UL approved ambient temperature 40 °C, refer to the 'Derating Curve'.
- It is for 100 - 240 VAC~ / VDC≐ power input only.

Model	SPB-A015-05	SPB-A015-12	SPB-A015-24	SPB-A030-05	SPB-A030-12	SPB-A030-24
Input	100 - 240 VAC~ / 90 - 350 VDC≐ (allowable voltage: 85 - 264 VAC~)					
Voltage⁽⁰¹⁾	100 - 240 VAC~ / 90 - 350 VDC≐ (allowable voltage: 85 - 264 VAC~)					
Current⁽⁰²⁾	115 VAC~ (Typical)	0.32 A 0.21 A	0.29 A 0.19 A	0.31 A 0.2 A	0.54 A 0.36 A	0.57 A 0.36 A
Frequency	50 / 60 Hz (allowable frequency: 47 - 63 Hz)					
Efficiency⁽⁰³⁾	115 VAC~ (Typical)	0.72 0.70	0.78 0.74	0.75 0.75	0.73 0.71	0.82 0.82
Power factor⁽⁰³⁾	115 VAC~ (Typical)	0.56 0.44	0.56 0.47	0.57 0.45	0.5 0.44	0.51 0.43
Power factor correction circuit (PFC)	Not available					
Inrush current⁽⁰⁴⁾	115 VAC~ (Typical)	16 A 32 A				
Leakage current (Typical)	115 VAC~ 230 VAC~	0.21 mA 0.28 mA			0.16 mA 0.25 mA	
Output	5 VDC≐, 12 VDC≐, 24 VDC≐, 5 VDC≐, 12 VDC≐, 24 VDC≐					
Voltage adjustment range	-10 to 15% (with VAdjust)					
Ripple⁽⁰⁵⁾	260 mV _{r,p} , 150 mV _{r,p} , 170 mV _{r,p} , 120 mV _{r,p} , 120 mV _{r,p} , 150 mV _{r,p}					
Input variation⁽⁰⁶⁾	≤ 0.5%					
Load variation⁽⁰⁷⁾	≤ 3.0%, ≤ 2.0%, ≤ 1.5%, ≤ 3.0%, ≤ 2.0%, ≤ 1.5%					
Temperature variation	≤ 0.05% / °C					
Start-up time⁽⁰⁸⁾	115 VAC~ (Typical)	720 ms 330 ms	810 ms 400 ms	820 ms 650 ms	580 ms 670 ms	650 ms 510 ms
Hold time⁽⁰⁹⁾	115 VAC~ (Typical)	32 ms 136 ms	33 ms 146 ms	43 ms 140 ms	33 ms 149 ms	29 ms 131 ms
Output low voltage indicate	4.2 V (± 10%), 9.6 V (± 10%), 20.0 V (± 10%), 4.2 V (± 10%), 9.6 V (± 10%), 20.0 V (± 10%)					
Unit weight (Package)	≈ 135 g (≈ 230 g), ≈ 170 g (≈ 265 g)					

Model	SPB-A060-12	SPB-A060-24	SPB-A120-12	SPB-A120-24
Input	100 - 240 VAC~ / 90 - 350 VDC≐ (allowable voltage: 85 - 264 VAC~)			
Voltage⁽⁰¹⁾	100 - 240 VAC~ / 90 - 350 VDC≐ (allowable voltage: 85 - 264 VAC~)			
Current⁽⁰²⁾	115 VAC~ (Typical)	1.05 A 0.6 A	1.1 A 0.7 A	1.3 A 0.7 A
Frequency	50 / 60 Hz (allowable frequency: 47 - 63 Hz)			
Efficiency⁽⁰³⁾	115 VAC~ (Typical)	0.81 0.82	0.85 0.87	0.82 0.84
Power factor⁽⁰³⁾	115 VAC~ (Typical)	0.54 0.46	0.54 0.46	0.99 0.92
Power factor correction circuit (PFC)	Not available			
Inrush current⁽⁰⁴⁾	115 VAC~ (Typical)	16 A 32 A		
Leakage current (Typical)	115 VAC~ 230 VAC~	0.16 mA 0.3 mA		0.3 mA 0.38 mA
Output	12 VDC≐, 24 VDC≐, 12 VDC≐, 24 VDC≐			
Voltage	12 VDC≐, 24 VDC≐, 12 VDC≐, 24 VDC≐			
Current	4.5 A, 2.5 A, 10 A, 5 A			
Power	54 W, 60 W, 120 W			
Power boost⁽⁰⁴⁾	120% of rated current			
Voltage adjustment range	-10 to 15% (with VAdjust)			
Ripple⁽⁰⁵⁾	460 mV _{r,p} , 110 mV _{r,p} , 470 mV _{r,p} , 310 mV _{r,p}			
Input variation⁽⁰⁶⁾	≤ 0.5%			
Load variation⁽⁰⁷⁾	≤ 2.0%, ≤ 1.5%, ≤ 2.0%, ≤ 1.5%			
Temperature variation	≤ 0.05% / °C			
Start-up time⁽⁰⁸⁾	115 VAC~ (Typical)	635 ms 655 ms	830 ms 770 ms	740 ms 710 ms
Hold time⁽⁰⁹⁾	115 VAC~ (Typical)	23 ms 106 ms	22 ms 103 ms	32 ms 31 ms
Output low voltage indicate	9.6 V (± 10%), 20.0 V (± 10%), 9.6 V (± 10%), 20.0 V (± 10%)			
Unit weight (Package)	≈ 230 g (≈ 325 g), ≈ 565 g (≈ 725 g)			

Model	SPB-A240-12	SPB-A240-24	SPB-A240-48	SPB-A480-24	SPB-A480-48
Input	100 - 240 VAC~ / 90 - 350 VDC≐ (allowable voltage: 85 - 264 VAC~)				
Voltage⁽⁰¹⁾	100 - 240 VAC~ / 90 - 350 VDC≐ (allowable voltage: 85 - 264 VAC~)				
Current⁽⁰²⁾	115 VAC~ (Typical)	2.5 A 1.3 A		4.8 A 2.4 A	
Frequency	50 / 60 Hz (allowable frequency: 47 - 63 Hz)				
Efficiency⁽⁰³⁾	115 VAC~ (Typical)	0.86 0.89	0.89 0.92	0.90 0.93	0.88 0.91
Power factor⁽⁰³⁾	115 VAC~ (Typical)	0.99 0.9		0.99 0.97	
Power factor correction circuit (PFC)	Available				
Inrush current⁽⁰⁴⁾	115 VAC~ (Typical)	16 A 32 A		40 A 55 A	
Leakage current (Typical)	115 VAC~ 230 VAC~	0.14 mA 0.25 mA		0.13 mA 0.24 mA	
Output	12 VDC≐, 24 VDC≐, 48 VDC≐, 24 VDC≐, 48 VDC≐				
Voltage	12 VDC≐, 24 VDC≐, 48 VDC≐, 24 VDC≐, 48 VDC≐				
Current	20 A, 10 A, 5 A, 20 A, 10 A				
Power	240 W, 480 W				
Power boost⁽⁰⁴⁾	120% of rated current				
Voltage adjustment range	-10 to 15% (with VAdjust)				
Ripple⁽⁰⁵⁾	430 mV _{r,p} , 300 mV _{r,p} , 360 mV _{r,p} , 270 mV _{r,p} , 320 mV _{r,p}				
Input variation⁽⁰⁶⁾	≤ 0.5%				
Load variation⁽⁰⁷⁾	≤ 2.0%, ≤ 1.5%, ≤ 1.5%				
Temperature variation	≤ 0.05% / °C				
Start-up time⁽⁰⁸⁾	115 VAC~ (Typical)	290 ms 250 ms	310 ms 250 ms	390 ms 290 ms	430 ms 300 ms
Hold time⁽⁰⁹⁾	115 VAC~ (Typical)	36 ms 39 ms	40 ms 3		