

# Product data sheet

Specifications



variable speed drive ATV310, 7.5 kW, 10 hp, 380...460 V, 3 phase, without filter

ATV310HU75N4E

## Main

Range of product	Easy Altivar 310
Product or component type	Variable speed drive
Product specific application	Simple machine
Assembly style	With heat sink
Device short name	ATV310
Network number of phases	Three phase
[Us] rated supply voltage	380...460 V - 15...10 %
Motor power kW	7.5 kW
Motor power hp	10 hp
Noise level	50 dB

## Complementary

Product destination	Asynchronous motors
Quantity per set	Set of 1
EMC filter	Without EMC filter
Type of cooling	Integrated fan
Supply frequency	50/60 Hz +/- 5 %
Communication port protocol	Modbus
Connector type	RJ45 (on front face) for Modbus
Physical interface	2-wire RS 485 for Modbus
Transmission frame	RTU for Modbus
Transmission rate	4800 bit/s 9600 bit/s 19200 bit/s 38400 bit/s
Number of addresses	1...247 for Modbus
Communication service	Read holding registers (03) 29 words Write single register (06) 29 words Write multiple registers (16) 27 words Read/write multiple registers (23) 4/4 words Read device identification (43)
Line current	22.4 A
Apparent power	17.8 kVA

<b>Prospective line I<sub>sc</sub></b>	5 kA
<b>Continuous output current</b>	17 A at 4 kHz
<b>Maximum transient current</b>	25.5 A for 60 s
<b>Power dissipation in W</b>	203.87 W at I <sub>n</sub>
<b>Speed drive output frequency</b>	0.5...400 Hz
<b>Nominal switching frequency</b>	4 kHz
<b>Switching frequency</b>	2...12 kHz adjustable
<b>Speed range</b>	1...20
<b>Transient overtorque</b>	170...200 % of nominal motor torque depending on drive rating and type of motor
<b>Braking torque</b>	Up to 150 % of nominal motor torque with braking resistor at high inertia Up to 70 % of nominal motor torque without braking resistor
<b>Asynchronous motor control profile</b>	Energy saving ratio Energy saving ratio Quadratic voltage/frequency ratio
<b>Motor slip compensation</b>	Adjustable Adjustable
<b>Output voltage</b>	380...460 V three phase
<b>Electrical connection</b>	Terminal, clamping capacity: 6...10 mm <sup>2</sup> (L1, L2, L3, PA+, PB, U, V, W)
<b>Tightening torque</b>	2.2...2.4 N.m
<b>Insulation</b>	Electrical between power and control
<b>Supply</b>	Internal supply for reference potentiometer: 5 V (4.75...5.25 V)DC, <10 mA with overload and short-circuit protection Internal supply for logic inputs: 24 V (20.4...28.8 V)DC, <100 mA with overload and short-circuit protection
<b>Analogue input number</b>	1
<b>Analogue input type</b>	Configurable current AI1 0...20 mA 250 Ohm Configurable voltage AI1 0...10 V 30 kOhm Configurable voltage AI1 0...5 V 30 kOhm
<b>Discrete input number</b>	4
<b>Discrete input type</b>	Programmable LI1...LI4 24 V 18...30 V
<b>Discrete input logic</b>	Negative logic (sink), > 16 V (state 0), < 10 V (state 1), input impedance 3.5 kOhm Positive logic (source), 0...< 5 V (state 0), > 11 V (state 1)
<b>Sampling duration</b>	10 ms for analogue input 20 ms, tolerance +/- 1 ms for logic input
<b>Linearity error</b>	+/- 0.3 % of maximum value for analogue input
<b>Analogue output number</b>	1
<b>Analogue output type</b>	AO1 software-configurable voltage: 0...10 V, impedance: 470 Ohm, resolution 8 bits AO1 software-configurable current: 0...20 mA, impedance: 800 Ohm, resolution 8 bits
<b>Discrete output number</b>	2
<b>Discrete output type</b>	Logic output LO+, LO- Protected relay output R1A, R1B, R1C 1 C/O
<b>Minimum switching current</b>	5 mA at 24 V DC for logic relay
<b>Maximum switching current</b>	2 A at 250 V AC on inductive load cos phi = 0.4 L/R = 7 ms for logic relay 2 A at 30 V DC on inductive load cos phi = 0.4 L/R = 7 ms for logic relay 3 A at 250 V AC on resistive load cos phi = 1 L/R = 0 ms for logic relay 4 A at 30 V DC on resistive load cos phi = 1 L/R = 0 ms for logic relay
<b>Acceleration and deceleration ramps</b>	S S U
<b>Braking to standstill</b>	By DC injection, <30 s
<b>Protection type</b>	Line supply overvoltage Line supply undervoltage Overcurrent between output phases and earth Overheating protection Short-circuit between motor phases Against input phase loss in three-phase

<b>Frequency resolution</b>	Analog input: converter A/D, 10 bits Display unit: 0.1 Hz
<b>Time constant</b>	20 ms +/- 1 ms for reference change
<b>Operating position</b>	Vertical +/- 10 degree
<b>Height</b>	232 mm
<b>Width</b>	150 mm
<b>Depth</b>	171 mm
<b>Net weight</b>	3.7 kg

## Environment

<b>Electromagnetic compatibility</b>	Electrical fast transient/burst immunity test - test level: level 4 conforming to EN/IEC 61000-4-4 Electrostatic discharge immunity test - test level: level 3 conforming to EN/IEC 61000-4-2 Immunity to conducted disturbances - test level: level 3 conforming to EN/IEC 61000-4-6 Radiated radio-frequency electromagnetic field immunity test - test level: level 3 conforming to EN/IEC 61000-4-3 Voltage dips and interruptions immunity test conforming to EN/IEC 61000-4-11 Surge immunity test - test level: level 3 conforming to EN/IEC 61000-4-5
<b>Standards</b>	EN/IEC 61800-3 EN/IEC 61800-5-1
<b>IP degree of protection</b>	IP20 without blanking plate on upper part IP40 top
<b>Pollution degree</b>	2 conforming to EN/IEC 61800-5-1
<b>Environmental characteristic</b>	Dust pollution resistance class 3S2 conforming to EN/IEC 60721-3-3 Chemical pollution resistance class 3C3 conforming to EN/IEC 60721-3-3
<b>Shock resistance</b>	15 gn conforming to EN/IEC 60068-2-27 for 11 ms
<b>Relative humidity</b>	5...95 % without condensation conforming to IEC 60068-2-3 5...95 % without dripping water conforming to IEC 60068-2-3
<b>Ambient air temperature for storage</b>	-25...70 °C
<b>Ambient air temperature for operation</b>	-10...55 °C without derating 55...60 °C protective cover from the top of the drive removed with current derating 2.2 % per °C
<b>Operating altitude</b>	<= 1000 m without derating

## Packing Units

<b>Unit Type of Package 1</b>	PCE
<b>Number of Units in Package 1</b>	1
<b>Package 1 Weight</b>	2.15 kg
<b>Package 1 Height</b>	23 cm
<b>Package 1 width</b>	20 cm
<b>Package 1 Length</b>	27 cm
<b>Unit Type of Package 2</b>	S04
<b>Number of Units in Package 2</b>	2
<b>Package 2 Weight</b>	8.956 kg
<b>Package 2 Height</b>	30 cm
<b>Package 2 width</b>	40 cm
<b>Package 2 Length</b>	60 cm
<b>Unit Type of Package 3</b>	P06
<b>Number of Units in Package 3</b>	8
<b>Package 3 Weight</b>	18.6 kg
<b>Package 3 Height</b>	74 cm

<b>Package 3 width</b>	60 cm
<b>Package 3 Length</b>	80 cm

## Offer Sustainability

<b>Sustainable offer status</b>	Green Premium product
<b>REACH Regulation</b>	<a href="#">REACH Declaration</a>
<b>EU RoHS Directive</b>	Compliant <a href="#">EU RoHS Declaration</a>
<b>Mercury free</b>	Yes
<b>RoHS exemption information</b>	Yes
<b>China RoHS Regulation</b>	<a href="#">China RoHS declaration</a>
<b>Environmental Disclosure</b>	<a href="#">Product Environmental Profile</a>
<b>Circularity Profile</b>	<a href="#">End of Life Information</a>
<b>WEEE</b>	The product must be disposed on European Union markets following specific waste collection and never end up in rubbish bins

**Dimensions**

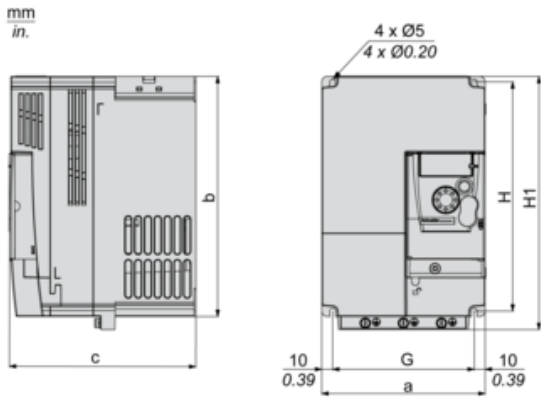

Dimensions in mm

a	b	c	G	H	H1	Ø	For screws
150	220	171	130	210	232	5	M4

Dimensions in in.

a	b	c	G	H	H1	Ø	For screws
5.91	8.66	6.73	5.12	8.27	9.13	0.20	M4

Mounting Recommendations

Clearance

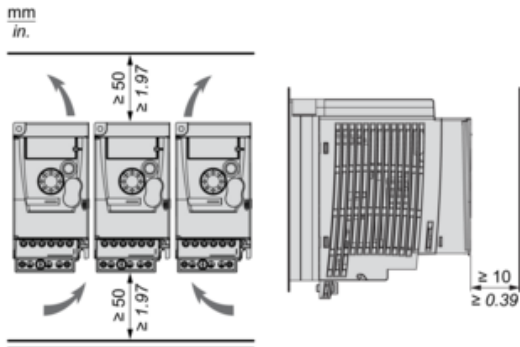

Mounting Types

Mounting Type A

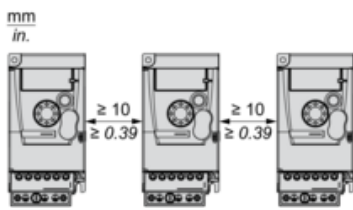

Mounting Type B

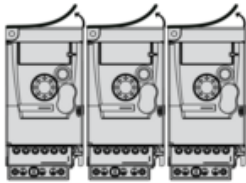

Remove the protective cover from the top of the drive.

Three-Phase Power Supply Wiring Diagram

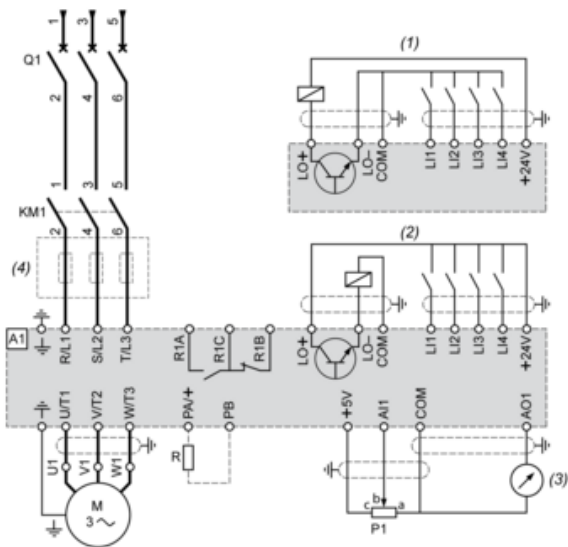

**A1** : Drive

**KM1** : Contactor (only if a control circuit is needed)

**P1** : 2.2 kΩ reference potentiometer. This can be replaced by a 10 kΩ potentiometer (maximum).

**Q1** : Circuit breaker

**R** : Braking resistor (optional)

(1) Negative logic (Sink)

(2) Positive logic (Source) (factory set configuration)

(3) 0...10 V or 0...20 mA

(4) Line choke three-phase (optional)