

Product data sheet

Specifications



variable speed drive ATV310, 22 kW, 30 hp, 380...460 V, 3 phase, without filter

ATV310HD22N4E

Main

Range of product	Easy Altivar 310
Product or component type	Variable speed drive
Product specific application	Simple machine
Assembly style	With heat sink
Device short name	ATV310
Network number of phases	Three phase
[Us] rated supply voltage	380...460 V - 15...10 %
Motor power kW	22 kW
Motor power hp	30 hp
Noise level	50 dB

Complementary

Product destination	Asynchronous motors
Quantity per set	Set of 1
EMC filter	Without EMC filter
Type of cooling	Integrated fan
Supply frequency	50/60 Hz +/- 5 %
Communication port protocol	Modbus
Connector type	RJ45 (on front face) for Modbus
Physical interface	2-wire RS 485 for Modbus
Transmission frame	RTU for Modbus
Transmission rate	4800 bit/s 9600 bit/s 19200 bit/s 38400 bit/s
Number of addresses	1...247 for Modbus
Communication service	Read holding registers (03) 29 words Write single register (06) 29 words Write multiple registers (16) 27 words Read/write multiple registers (23) 4/4 words Read device identification (43)
Line current	64.2 A 71.2 A
Apparent power	46.2 kVA

	47 kVA
Prospective line I_{sc}	22 kA 5 kA
Continuous output current	46 A at 4 kHz 60 A at 4 kHz
Maximum transient current	69 A for 60 s 66 A for 60 s
Power dissipation in W	539.4 W at I _n 736.7 W at I _n
Speed drive output frequency	0.5...400 Hz
Nominal switching frequency	4 kHz
Switching frequency	2...12 kHz adjustable
Speed range	1...20
Transient overtorque	170...200 % of nominal motor torque depending on drive rating and type of motor
Braking torque	Up to 150 % of nominal motor torque with braking resistor at high inertia Up to 70 % of nominal motor torque without braking resistor
Asynchronous motor control profile	Quadratic voltage/frequency ratio Energy saving ratio Sensorless flux vector control
Motor slip compensation	Preset in factory Adjustable
Output voltage	380...460 V three phase
Electrical connection	Terminal, clamping capacity: 10 mm ² (L1, L2, L3, PA/+, PB, U, V, W)
Tightening torque	2.2...2.4 N.m
Insulation	Electrical between power and control
Supply	Internal supply for reference potentiometer: 5 V (4.75...5.25 V)DC, <10 mA with overload and short-circuit protection Internal supply for logic inputs: 24 V (20.4...28.8 V)DC, <100 mA with overload and short-circuit protection
Analogue input number	1
Analogue input type	Configurable current AI1 0...20 mA 250 Ohm Configurable voltage AI1 0...10 V 30 kOhm Configurable voltage AI1 0...5 V 30 kOhm
Discrete input number	4
Discrete input type	Programmable LI1...LI4 24 V 18...30 V
Discrete input logic	Negative logic (sink), > 16 V (state 0), < 10 V (state 1), input impedance 3.5 kOhm Positive logic (source), 0...< 5 V (state 0), > 11 V (state 1)
Sampling duration	10 ms for analogue input 20 ms, tolerance +/- 1 ms for logic input
Linearity error	+/- 0.3 % of maximum value for analogue input
Analogue output number	1
Analogue output type	AO1 software-configurable voltage: 0...10 V, impedance: 470 Ohm, resolution 8 bits AO1 software-configurable current: 0...20 mA, impedance: 800 Ohm, resolution 8 bits
Discrete output number	2
Discrete output type	Logic output LO+, LO- Protected relay output R1A, R1B, R1C 1 C/O
Minimum switching current	5 mA at 24 V DC for logic relay
Maximum switching current	2 A at 250 V AC on inductive load cos phi = 0.4 L/R = 7 ms for logic relay 2 A at 30 V DC on inductive load cos phi = 0.4 L/R = 7 ms for logic relay 3 A at 250 V AC on resistive load cos phi = 1 L/R = 0 ms for logic relay 4 A at 30 V DC on resistive load cos phi = 1 L/R = 0 ms for logic relay
Acceleration and deceleration ramps	U S Linear from 0...999.9 s
Braking to standstill	By DC injection, <30 s
Protection type	Line supply overvoltage

Line supply undervoltage
 Overcurrent between output phases and earth
 Overheating protection
 Short-circuit between motor phases
 Against input phase loss in three-phase
 Thermal motor protection via the drive by continuous calculation of I²t

Frequency resolution	Analog input: converter A/D, 10 bits Display unit: 0.1 Hz
Time constant	20 ms +/- 1 ms for reference change
Operating position	Vertical +/- 10 degree
Height	390 mm
Width	180 mm
Depth	212 mm
Net weight	8.5 kg

Environment

Electromagnetic compatibility	Electrical fast transient/burst immunity test - test level: level 4 conforming to EN/IEC 61000-4-4 Electrostatic discharge immunity test - test level: level 3 conforming to EN/IEC 61000-4-2 Immunity to conducted disturbances - test level: level 3 conforming to EN/IEC 61000-4-6 Radiated radio-frequency electromagnetic field immunity test - test level: level 3 conforming to EN/IEC 61000-4-3 Voltage dips and interruptions immunity test conforming to EN/IEC 61000-4-11 Surge immunity test - test level: level 3 conforming to EN/IEC 61000-4-5
Standards	EN/IEC 61800-5-1 EN/IEC 61800-3
IP degree of protection	IP20 without blanking plate on upper part IP40 top
Pollution degree	2 conforming to EN/IEC 61800-5-1
Environmental characteristic	Dust pollution resistance class 3S2 conforming to EN/IEC 60721-3-3 Chemical pollution resistance class 3C3 conforming to EN/IEC 60721-3-3
Shock resistance	15 gn conforming to EN/IEC 60068-2-27 for 11 ms
Relative humidity	5...95 % without condensation conforming to IEC 60068-2-3 5...95 % without dripping water conforming to IEC 60068-2-3
Ambient air temperature for storage	-25...70 °C
Ambient air temperature for operation	-10...55 °C without derating 55...60 °C protective cover from the top of the drive removed with current derating 2.2 % per °C
Operating altitude	<= 1000 m without derating

Packing Units

Unit Type of Package 1	PCE
Number of Units in Package 1	1
Package 1 Weight	9.5 kg
Package 1 Height	21.2 cm
Package 1 width	18 cm
Package 1 Length	33 cm
Unit Type of Package 2	P06
Number of Units in Package 2	6
Package 2 Weight	73.0 kg
Package 2 Height	105 cm
Package 2 width	60 cm
Package 2 Length	80 cm

Offer Sustainability

Sustainable offer status	Green Premium product
REACH Regulation	REACH Declaration
EU RoHS Directive	Compliant EU RoHS Declaration
Mercury free	Yes
RoHS exemption information	Yes
China RoHS Regulation	China RoHS declaration
Environmental Disclosure	Product Environmental Profile
Circularity Profile	End of Life Information
WEEE	The product must be disposed on European Union markets following specific waste collection and never end up in rubbish bins
California proposition 65	WARNING: This product can expose you to chemicals including: Lead and lead compounds, which is known to the State of California to cause cancer and birth defects or other reproductive harm. For more information go to www.P65Warnings.ca.gov
Upgradeability	Upgraded components available 

Dimensions

Side and Front Sides

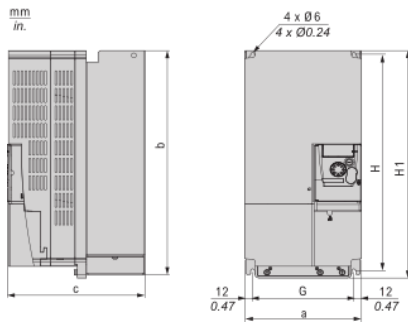

Dimensions in mm

a	b	c	G	H	H1	Ø	For screws
180	384.5	212	156	371.5	390	6	M5

Dimensions in in.

a	b	c	G	H	H1	Ø	For screws
7.09	15.14	8.35	6.14	14.63	15.35	0.23	M5

Mounting Recommendations

Clearance

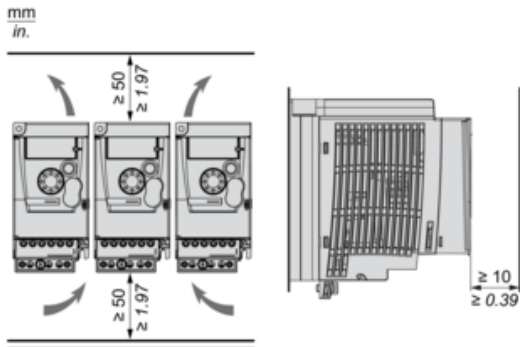

Mounting Types

Mounting Type A

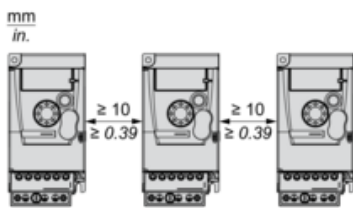

Mounting Type B

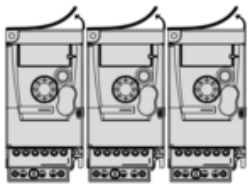

Remove the protective cover from the top of the drive.

Three-Phase Power Supply Wiring Diagram

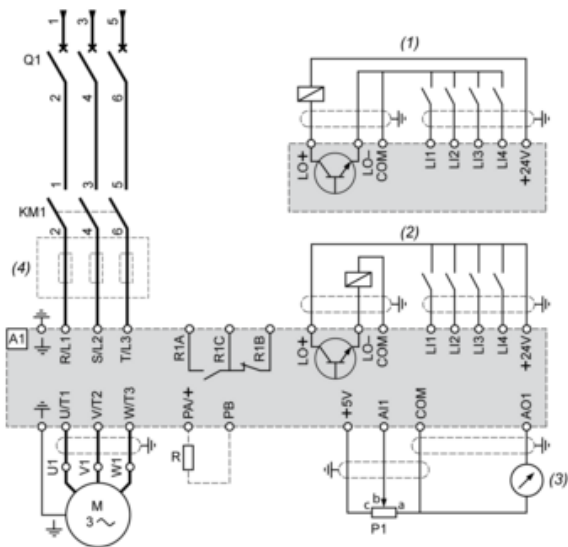

A1 : Drive

KM1 : Contactor (only if a control circuit is needed)

P1 : 2.2 kΩ reference potentiometer. This can be replaced by a 10 kΩ potentiometer (maximum).

Q1 : Circuit breaker

R : Braking resistor (optional)

(1) Negative logic (Sink)

(2) Positive logic (Source) (factory set configuration)

(3) 0...10 V or 0...20 mA

(4) Line choke three-phase (optional)